

Devola®

DEHUMIDIFIER INSTRUCTION MANUAL

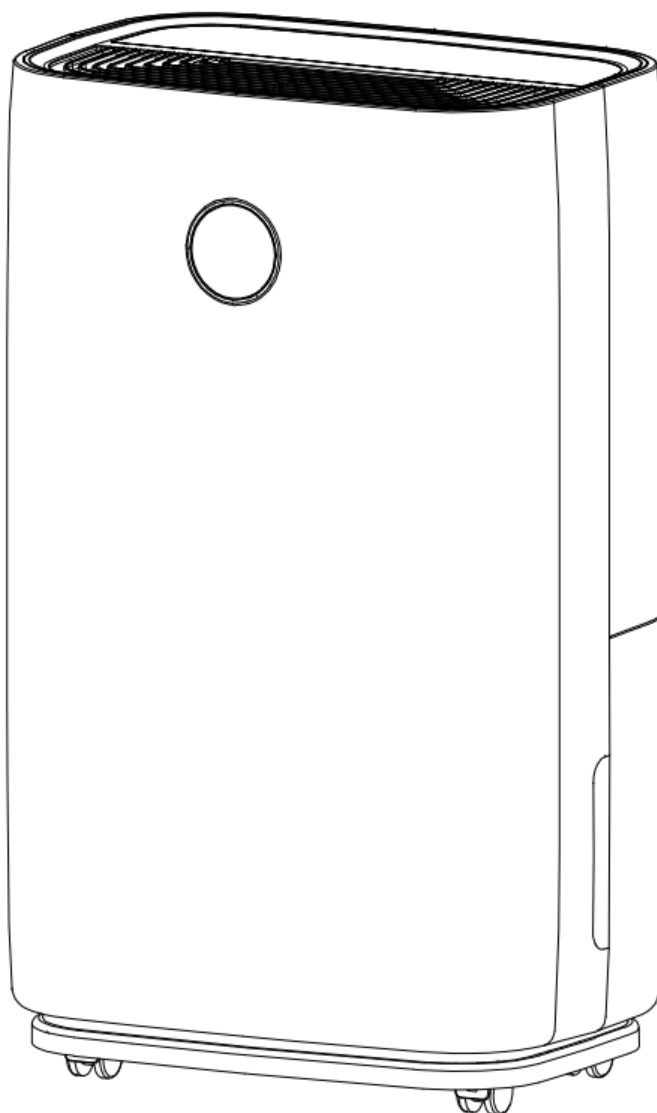

Model (s):

DV16L/DV16LWF

DV20L/DV20LWF



Please keep this manual carefully for future reference!

Thank you for purchasing our Devola dehumidifier. Be sure to read this manual carefully before using it. Any questions, please contact a professional service, or alternatively our customer service team for help.

1. BEFORE YOU BEGIN

Please read the operating instructions carefully before using your dehumidifier for the first time.

1.1 PRODUCT DESCRIPTION





The dehumidifier is used to remove excessive moisture from the air. The resulting reduction in relative humidity protects buildings and their contents from the adverse effects of excess humidity.

The environmentally friendly R290 is used as the refrigerant. R290 has no damaging influence on the ozone layer (ODP), a negligible greenhouse effect (GWP) and is available worldwide.

Because of its efficient energy properties, R290 is highly suitable as a coolant for this application.

Special precautions must be taken into consideration due to the coolant's high flammability.

SYMBOLS FROM THE UNIT AND USER MANUAL

 warning	This unit uses a flammable refrigerant. If the refrigerant leaks and comes in contact with fire or another heating source, it will create a harmful gas and there is risk of fire.
	Read the USER MANUAL carefully before operation.
	Further information is available in the USER MANUAL, SERVICE MANUAL, and the like.
	Service personnel are required to carefully read the USER MANUAL and SERVICE MANUAL before operation.

1.2 THE FOLLOWING SHOULD ALWAYS BE OBSERVED FOR SAFETY

- This appliance is intended for domestic use but can also be for commercial use if the environment is safe to do so.
- This appliance can be used by children aged 8 years and above. It can also be used by individuals with reduced physical, sensory, or mental capabilities if they have been given supervision or instruction concerning use of the appliance in a safe way and understand the hazards involved. Children aged below 8 years should not play with or use the appliance. Cleaning and user maintenance should not be made by children 8 years and above without supervision.
- The unit is designed only for use with R-290 (propane) gas as the designated refrigerant.
- The refrigerant loop is sealed. Only a qualified technician should attempt to service!
- Do not discharge the refrigerant into the atmosphere.
- R-290 (propane) is flammable and heavier than air.
- It collects first in low areas but can be circulated by the fans.
- If propane gas is present or even suspected, do not allow untrained personnel to attempt to find the cause.
- The propane gas used in the unit has no odor.
- The lack of smell does not indicate a lack of escaped gas.
- If a leak is detected, immediately evacuate all persons from the device's location and contact the local fire department to advise them that a propane leak has occurred.
- Do not let any persons back into the room until the qualified service technician has arrived and that technician advises that it is safe to return to the device location.
- No open flames, cigarettes or other possible sources of ignition should be used inside or in the vicinity of the units.
- Component parts are designed for propane and non-incentive and non-sparking. Component parts should only be replaced with identical repair parts.

FAILURE TO ABIDE BY THESE WARNING COULD RESULT IN AN EXPLOSION, DEATH, INJURY AND PROPERTY DAMAGE.



2. FOR YOUR SAFETY

Your safety is of utmost concern to us!



Please read this manual carefully and fully understand before operating your dehumidifier.

2.1 OPERATIONAL PRECAUTIONS

WARNING- to reduce the risk of fire, electric shock or injury to persons or property:

- If the supply cord is damaged, it must be replaced by the manufacturer, its service agent or similarly qualified persons to avoid a hazard.
- The appliance should be disconnected from its power source during maintenance.
- Always operate the unit from a power source of equal voltage, frequency and rating as indicated on the product rating label.
- Always use a power outlet that is grounded.
- Unplug the power cord when cleaning or when not in use.
- Do not operate with wet hands. Prevent water from spilling onto the unit.
- Do not immerse or expose the unit to rain, moisture or any other liquid.
- Do not leave the unit running unattended. Do not tilt or turn over the unit.
- Do not unplug while the unit is operating.
- Do not unplug by pulling on the power cord.
- Do not use an extension cord or an adapter plug.

- Do not put objects on the unit.
- Do not climb or sit on the unit.
- Do not insert fingers or other objects into the air outlet.
- Do not touch the air inlet or the aluminum fins of the unit.
- Do not operate the unit if it is dropped, damaged or showing signs of product malfunction.
- Do not clean the appliance with any chemicals.
- Ensure the unit is far away from fire, inflammable, or explosive objects.
- The unit should be installed in accordance with national wiring regulations.
- Do not use means to accelerate the defrosting process or to clean, other than those recommended by the manufacture.
- The appliance should be stored in a room without continuously operation sources (for example: open flames, an operating gas appliance or an operating electric heater).
- The appliance should be stored when out of use for long periods, to prevent mechanical damage from occurring.
- Do not piece or burn, even after use.
- Be aware that refrigerants may not contain an odor.
- Pipework should be protected from physical damage and should not be installed in an unventilated space, if that space is smaller than 4m².
- Compliance with national gas regulations should be observed.
- Keep any required ventilation openings clear of obstruction.
- The appliance should be stored in a well-ventilated area where the room size corresponds to the room area as specified for operation.



Any person who is involved with working on or breaking into a refrigerant circuit should hold a current valid certificate from an industry-accredited assessment authority, which authorizes their competence to handle refrigerants safely in accordance with an industry, recognized assessment specification.



Servicing should only be performed as recommended by the equipment manufacturer. Maintenance and repair requiring the assistance of other skilled personnel should be carried out under the supervision of the person competent in the use of flammable refrigerants.

If you do not understand something or need help, please contact the dealer services

2.2 SAFETY PRECAUTIONS ON SERVICING

Please follow these warnings when to undertake the following when servicing a dehumidifier with R290.

2.2.1 Checks to the area

Prior to beginning work on systems containing flammable refrigerants, safety checks are necessary to ensure that the risk of ignition is minimized. For repair to the refrigerating system, the following precautions should be complied with prior to conducting work on the system.

2.2.2 Work procedure

Work should be undertaken under a controlled procedure to minimize the risk of a flammable gas or vapor being present while the work is being performed.

2.2.3 General work area

All maintenance staff and others working in the local area should be instructed on the nature of work being carried out. Work in confined spaces should be avoided. The area around the workspace should be sectioned off. Ensure that the conditions within the area have been made safe by control of flammable material.

2.2.4 Checking for presence of refrigerant

The area should be checked with an appropriate refrigerant detector prior to and during work, to ensure the technician is aware of potentially flammable atmospheres. Ensure that the leak detection equipment being used is suitable for use with flammable refrigerants, i.e. no sparking, adequately sealed or intrinsically safe.

2.2.5 Presence of fire extinguisher

If any hot work is to be conducted on the refrigeration equipment or any associated parts, appropriate fire extinguishing equipment should be available to hand. Have a dry powder or CO₂ fire extinguisher adjacent to the charging area.

2.2.6 No ignition sources

No person carrying out work in relation to a refrigeration system which involves exposing any pipework that contains or has contained flammable refrigerant should use any sources of ignition in such a manner that it may lead to the risk of fire or explosion. All possible ignition sources, including cigarette smoking, should be kept sufficiently far away from the site of installation, repairing, removing and disposal, during which flammable refrigerant can possibly be released to the surrounding space. Prior to work taking place, the area around the equipment is to be surveyed to make sure that there are no flammable hazards or ignition risks. "No Smoking" signs should be displayed.

2.2.7 Ventilated area

Ensure that the area is in the open or that it is adequately ventilated before breaking into the system or conducting any hot work. A degree of ventilation should continue during the period that the work is carried out. The ventilation should safely disperse any released refrigerant and preferably expel it externally into the atmosphere.

2.2.8 Checks to the refrigeration equipment

Where electrical components are being changed, they should be fit for the purpose and to the correct specification. At all times, the manufacturer's maintenance and service guidelines should be followed. If in doubt consult the manufacturer's technical department for assistance.

The following checks should be applied to installations using flammable refrigerants:

- The charge size is in accordance with the room size within which the refrigerant containing parts are installed.
- The ventilation machinery and outlets are operating adequately and are not obstructed.
- If an indirect refrigerating circuit is being used, the secondary circuit should be checked for the presence of refrigerant.
- Marking to the equipment continues to be visible and legible. Markings and signs that are illegible should be corrected.

– refrigeration pipe or components are installed in a position where they are unlikely to be exposed to any substance which may corrode refrigerant containing components, unless the components are constructed of materials which are inherently resistant to being corroded or are suitably protected against being so corroded.

2.2.9 Checks to electrical devices

Repair and maintenance to electrical components should include initial safety checks and component inspection procedures. If a fault exists that could compromise safety, then no electrical supply should be connected to the circuit until it is satisfactorily dealt with. If the fault cannot be corrected immediately but it is necessary to continue operation, an adequate temporary solution should be used. This should be reported to the owner of the equipment, so all parties are advised.

Initial safety checks should include:

- those capacitors are discharged: this should be done in a safe manner to avoid possibility of sparking.
- that there no live electrical components and wiring are exposed while charging, recovering, or purging the system.
- that there is continuity of earth bonding

3. PRODUCT OVERVIEW

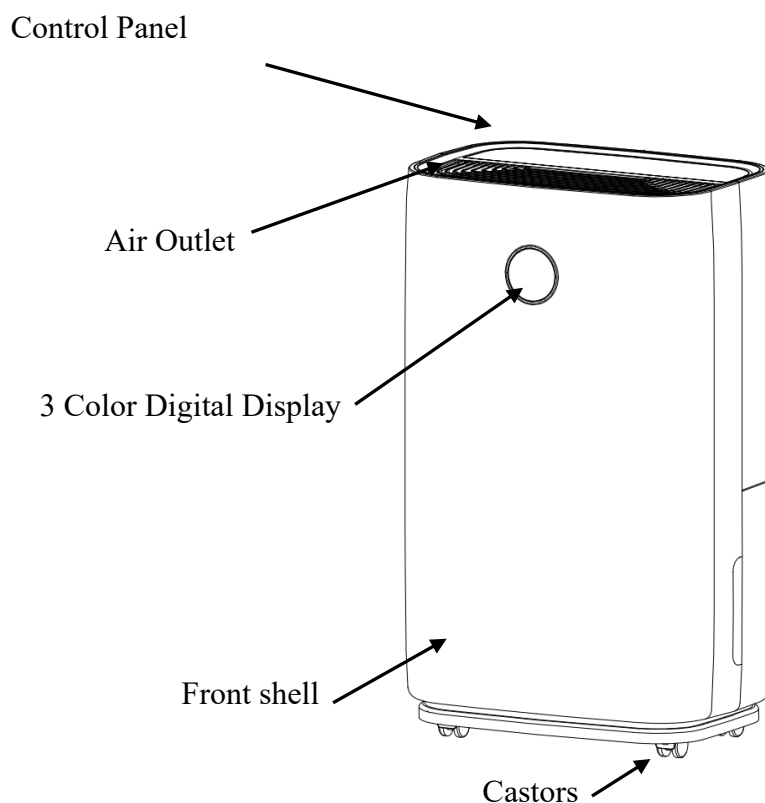

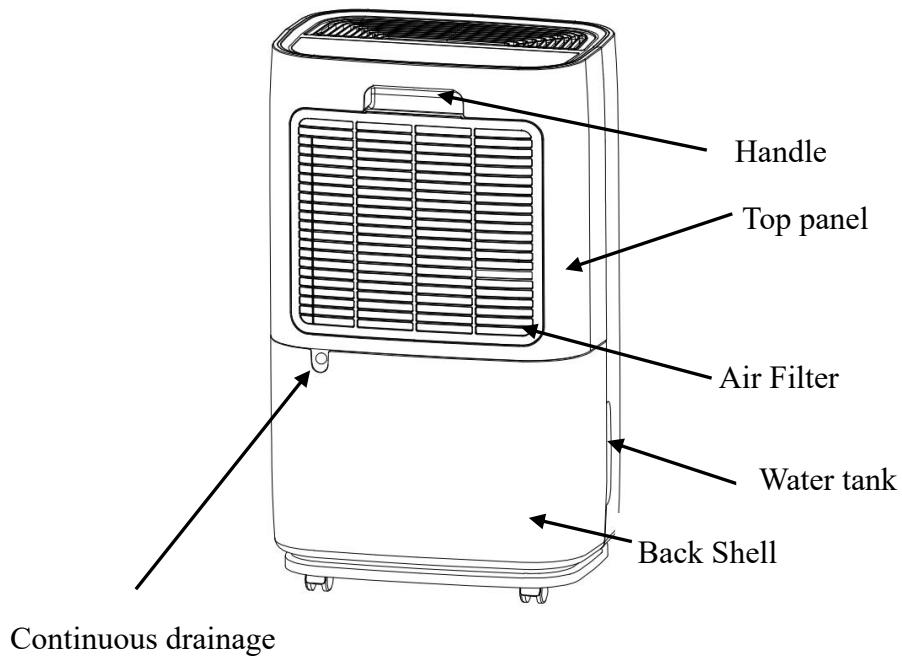

3.1 FEATURES

- ✓ Powerful moisture removal (up to 20L/day dehumidification)
- ✓ Humidity Monitor shows current air humidity
- ✓ Auto mode automatically adjusts humidity levels
- ✓ A 12-hour timer to set the time of operation
- ✓ Effectively removes moisture, dust from the air
- ✓ Low power consumption-energy efficient
- ✓ Quiet fan has two speed settings
- ✓ Auto-Defrost at low temperature
- ✓ Auto shut-off/ auto restart
- ✓ Electronic control
- ✓ Laundry drying function
- ✓ Antibacterial Filter
- ✓ Continuous drainage or 4L water tank
- ✓ Wi-Fi Function (Applicable to DV16LWF and DV20LWF only)

4. INSTALLATION

4.1 LOCATION

1. Place the unit on a firm, level surface in an area with at least 30cm of free space around it to allow for proper air circulation.
2. Never install the unit where it could be subject to:
 - Heat sources such as radiators, heat registers, stoves or other products that produce heat.
 - In an area where oil or water may be splashed
 - Direct sunlight
 - Mechanical vibration or shock
 - Excessive dust
 - Lack of ventilation, such as cabinet or bookcase
 - Uneven surface

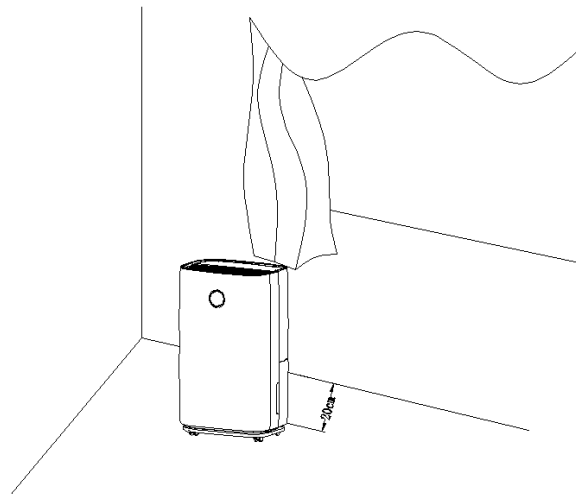

WARNING

Install the unit in rooms which exceed 4m².

Do not install the unit in a place where inflammable gas may leak.

4.2 OPERATING THE DEVICE SAFELY

1. Check the device after unpacking for any damage or scratches on it.
2. Operate this unit in an ambient temperature from 5°C to 35°C.
3. Do not use the unit outdoors. This dehumidifier is intended for indoor use only.
4. Do not operate near walls, curtains, or other objects that may block inlet and outlet.
5. Keep the air inlet and outlet free of obstacles.
6. Adjust the wind deflector in the upward direction prior to start up.
7. If tipped more than 45°, allow the unit to sit upright for at least 24 hours before start up.
8. Keep doors and windows closed for better efficiency savings.
9. Do not operate or store the unit in direct sunlight or rain.
10. It is normal for air outlet to feel warm to touch after continuous operation on hot days.
11. Empty the water tank before moving the device.
12. Make sure the water tank is correctly fitted otherwise the unit will not operate properly.
13. The dehumidifier starts up in the mode selected when the unit was last used.
14. The dehumidifier starts dehumidifying if the room humidity is 3% higher than the selected humidity.

There is a protective 3-minutes time delay of the compressor. Wait 3 minutes for the dehumidifier to resume dehumidification.

5. OPERATION

5.1 DIGITAL DISPLAY



5.2 CONTROL PANEL



5.3 SETTINGS

Power

In the standby state, press the power button to turn on, the operation indicator lights up and the default fan speed is high, the LED shows ambient humidity. In the power-on state, press the power button to turn off, the running indicator light goes off and the compressor stops immediately, and then the fan will shut down after 30 seconds.

Mode

There are three modes: Auto mode, continuous drying mode, and a sleeping cycle mode. Press once to switch the mode from one to another, the corresponding indicator lights up.

- **Auto mode:** when the environmental humidity set is $\geq +3\%$, the fan starts working and compressor starts working after 3 seconds. When environmental humidity \leq set humidity -3% , the compressor stops working and fan stops working after 30 seconds.

Both fan speed and humidity can be adjusted under auto mode.

- **Continuous drying mode:** The machine continues to run, but the humidity cannot be adjusted.

● **Sleeping mode:** Touch the sleep button, the button lights up and the sleep function will be activated. Press and hold the sleep button for 3 seconds to reset the filter.

Timer

Press the timer button to set the 0-12-hour timing function. The timer can only be set in 1-hour increments. Each time you press this button, the value increases by 1 hour and then the corresponding timing value is displayed on the screen. The setting value is “00” to cancel the timer function. After the timer is set and completed, the timer LED is on during the timing period. After the timer is over, the timer LED turns off automatically.

In the running state, set the time to turn off the machine.

In the standby state, set the time to turn on the machine.

Note: pressing POWER will also cancel the shutdown timer setting.

Speed

The speed can only be adjusted in automatic mode. Touch the speed button to switch between high and low fan speed.

Up

Press this button to set the humidity and timer;

Humidity adjusting the order of 30% to 35% - 40% - 45% - 50% - 55% - 60% - 65% - 70% - 75% - 80% - 30%;

To set the timer press the timer button and 00 will flash on the digital display, then press the key repeatedly until you reach your desired time.

Down

Press this button to lower the humidity setting or timer time;

Humidity adjusting the order of 30% to 80% - 75% - 70% - 65% - 60% - 55% - 50% - 45% - 40% - 35% - 30%;

When setting the timer, if you accidentally go beyond your desired time you can use the down button to cycle backwards.

Child-lock

When the machine is turned on, press the button for 3 seconds to open/close the child lock function. When the button is turned on, the indicator light of the child lock is on. When the child lock function is active it will be cancelled automatically if the device is shutdown or a power failure occurs.

WIFI (Optional) --Timer key

Information on the App [“Smart Life-Smart Living”](#)

The [“Smart Life-Smart Living”](#) app is available for android and iOS.

Scan the corresponding QR code to directly download.

Note: Depending on the provider, there may be costs incurred when downloading the app.



Information on How to Use the App

This appliance allows you to operate the appliance via your home network. A prerequisite is a permanent Wi-Fi connection to your router and the app **“Smart Life-Smart Living”**.



We recommend disconnecting the appliance from the power supply when you are away from home to prevent unintentional switching on in your absence.

System Requirements for Use of the App

iOS 8.0 or higher

Android 4.1 or higher

Using the App

1. Install the **“Smart Life-Smart Living”** app. Create a user account.
2. Activate the Wi-Fi function in the settings of your appliance.
3. Place the appliance within 5 meters of your router.
4. Press and hold the Timer button for about 5 seconds and the Wi-Fi indicator will flash rapidly.
5. Launch the app and select “+”.

6. Go to Small Home Appliances, select “Air Conditioner” and follow the instructions on your device.
7. Once the appliance has been successfully connected, the Wi-Fi indicator will illuminate. Now you can operate the appliance using the app.
8. Press and hold the Timer button for about 5 seconds, the appliance disconnects and the Wi-Fi indicator will switch off.

5.4 DRAINAGE

There are two ways of removing collected water produced by the unit.

- A. Manual draining: Empty water tank manually.
- B. Continuous draining: Allowing the water to flow out of the appliance by attaching a drain hose.

5.3.1 EMPTYING THE WATER TANK

The appliance will shutdown once the water tank has reached its full capacity. The unit will only start up again when the water tank is emptied and has been re-installed correctly.

- 1) When the tank is full, the unit will make a buzzing sound, and the “Water Full” light will turn on.
- 2) Press the POWER button to turn off the unit.
- 3) Pull on the water tank and simply slide out of the body of the dehumidifier.
- 4) Empty the water into an area with a drain or outside.
- 5) Clean the inside of the tank as well as the outside.
- 6) Replace the empty tank back into the unit.
- 7) Press the POWER button to resume operating.
- 8) If the Water Full light does not extinguish, check that the tank is correctly in place.

1. Pull out the water tank

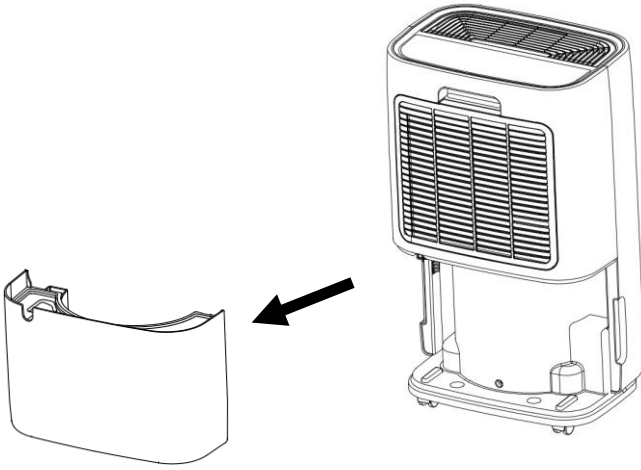

2. Empty the water tank

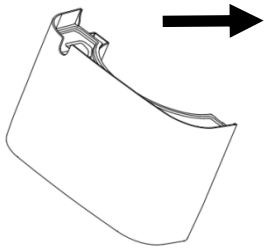

3. Replace the empty tank back into the unit

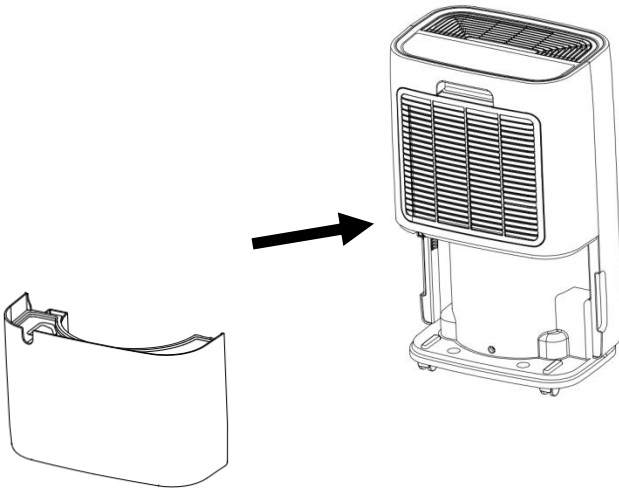

Warning!

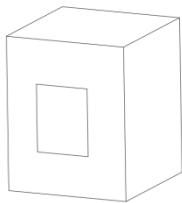

- Do not discard the magnets and plastic rivets in the tank. Otherwise, the dehumidifier cannot be started, or the machine will not automatically stop working when the water tank is full, and the condensed water overflow will damage the floor of the room.
- Please make sure to clean the condensed water in the tank and put the tank in its correct operating position.
- If the water tank is dirty, please rinse it with clean water. Avoid using detergents, steel wire balls, chemical dust removers, diesel, benzene, diluents or other solvents. These products can damage the tank and cause leaks.
- Put the water tank in its original position. Otherwise, the indicator light will be red, and the machine will start working again.

Continuous Drainage:

1. Take out the PVC pipe, straighten the drainpipe.
2. Insert one end of the drainpipe into the drain outlet at the top of the tank and connect the other end to the bathroom, floor drain, outdoor or bucket like container.

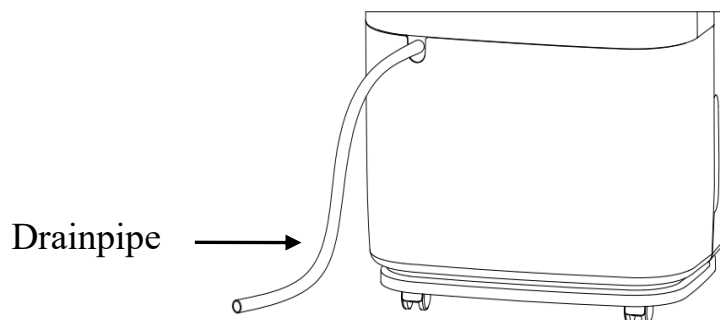



Warning

1. Please do not block the drain or drainpipe. If a blockage occurs the condensed water will flow into the tank.
2. Please do not bend the drainpipe. The height of the drainpipe should be lower than the outlet.
3. The drainpipe must be firmly connected to the outlet.

6. MAINTENANCE

Note: Before carrying out cleaning and maintenance on the appliance, please be sure to turn off the machine and unplug it from its power source to avoid electric shock.

CLEANING THE AIR FILTER (every two weeks)

Dust collects on the filter and restricts the airflow. The restricted airflow reduces the efficiency of the system and if it becomes blocked it can cause damage to the unit.

The air filter requires regular cleaning. The air filter is removable for easy cleaning. Do not operate the unit without an air filter, or the evaporator may be contaminated.

Switch off the unit and remove air filter as below.

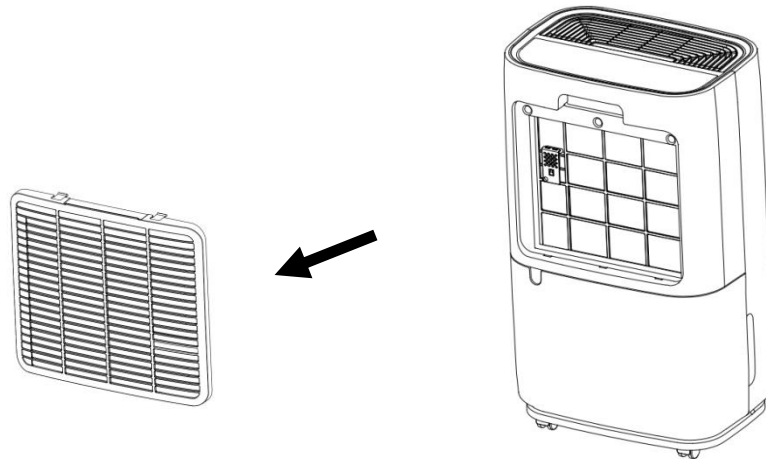

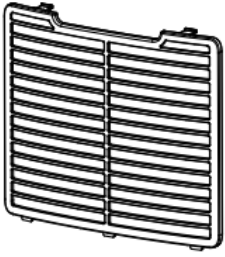

Rinse under running water or using the vacuum to clean the dust.

Reassemble the air filter.

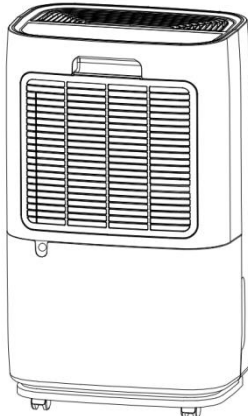
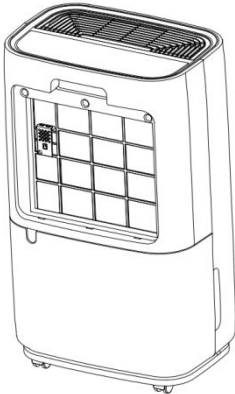

TROUBLESHOOTING

SYMPTOM		INSPECTION	SOLUTION
The unit is not operating.		✓ Check the power connection in secure.	➤ Insert the power cord securely into the wall outlet.
		✓ Check if the water level indicator light is illuminated.	➤ Empty the water tank and reinstall correctly.
		✓ Check the room temperature.	➤ The operating temperature range is 5-35°C.
There is little formation of condensate.		✓ Check the air filter for dirt.	➤ Clean the air filter as necessary.
		✓ Check if the air duct is blocked.	➤ To clear the obstacle.
		✓ Check if the room temperature is below 20°C.	➤ This is normal. Low humidity in low temperature environment.
		✓ Set humidity level is higher than current humidity value.	➤ Set the humidity level below current humidity value.
Water Leakage		✓ Overflow while moving the unit.	➤ Empty the water tank before transporting the unit.
		✓ Check if the drain hose is kinked or bent.	➤ Straighten the hose to avoid a trap existing.
Excessive Noise		✓ Check if the unit is securely positioned.	➤ Place the unit on horizontal, firm and flat ground.
		✓ Check for any loose or vibrating parts.	➤ Secure and tighten the parts.
		✓ Noise sounds like water flowing.	➤ Noise comes from flowing refrigerant. This is normal.
Error code	E2	✓ Humidity sensor dampened or failure.	➤ Clean or replace the humidity sensor.
	CL	✓ Display when Room temperature is below 5°C (41°F) .	➤ Normal. The compressor stops, and the fan keeps running.
	CH	✓ Display when Room temperature is above 38°C (100°F) .	➤ Normal. The compressor stops, and the fan keeps running.
	LO	✓ Display when Room relative humidity is below 20%RH.	➤ Normal. The compressor stops, and the fan keeps running.
	HI	✓ Display when room relative humidity is above 90%RH.	➤ Normal. The compressor and the fan keep running.

WARRANTY

Guarantee and service policy

This product is covered by a standard parts or replacement warranty for a period of 12 months from the date of purchase.

Extend your warranty for 12 months for free by visiting www.devola.co.uk/warranty.

Incorrect installation and failure to follow correct operating instructions are excluded. Consequential costs such as labour charges or damage to surroundings are expressly excluded.

Contact Us

If you experience a problem with this product you should first contact us on 0121 250 2180 before taking any further action.

CLAIM YOUR EXCLUSIVE 5% OFF YOUR NEXT ONLINE ORDER

DISCOUNT CODE: DEV5

OFFER VALID FOR 21 DAYS. DON'T MISS OUT!

YOUR DISCOUNT CODE ALSO APPLIES TO OUR SISTER WEBSITES

Visit our websites:

www.devola.co.uk

www.energybulbs.co.uk

www.airconcentre.co.uk

www.ledbulbs.co.uk