



**EH1826**

PremlAir 16" (40 cm)  
Oscillating and Height  
Adjustable 3 Speed Pedestal  
Fan with Remote Control and  
Timer



**User Manual**

Please Retain for Future  
Reference

## IMPORTANT

### Installer and Users please note:

These instructions should be read carefully and left with the user of the product for future reference.

## BEFORE USE

You must inspect the appliance including its cable and plug for any signs of damage. If the product is damaged, DO NOT use it, and contact your supplier immediately.

## PRODUCT SAFETY

- This appliance can be used by children aged from 8 years and above and persons with reduced physical, sensory or mental capabilities or lack of experience and knowledge if they have been given supervision or instruction concerning use of the appliance in a safe way and understand the hazards involved.
- Children shall not play with the appliance.
- Cleaning and user maintenance shall not be made by children without supervision.
- Place the appliance on a firm flat surface. Do not place on soft surfaces.
- For indoor use only.
- Do not use in close proximity to gas appliances.
- Do not use the appliance in locations where paint, petrol or other flammable liquids are used or stored.
- Do not move the appliance whilst it is operating.
- Do not use in bathrooms, or in wet or damp locations.
- Do not use this appliance in the immediate surroundings of a bath, a shower or a swimming pool.
- Do not place the mains lead beneath a carpet or rug.
- Do not insert any object into the appliance through the grilles. This may damage the appliance or result in overheating or electric shock.
- The appliance is fitted with an overload cut-out which will operate if the motor overheats or is stalled. If this happens, disconnect from the mains supply immediately, and allow the motor to cool down.

## ASSEMBLY

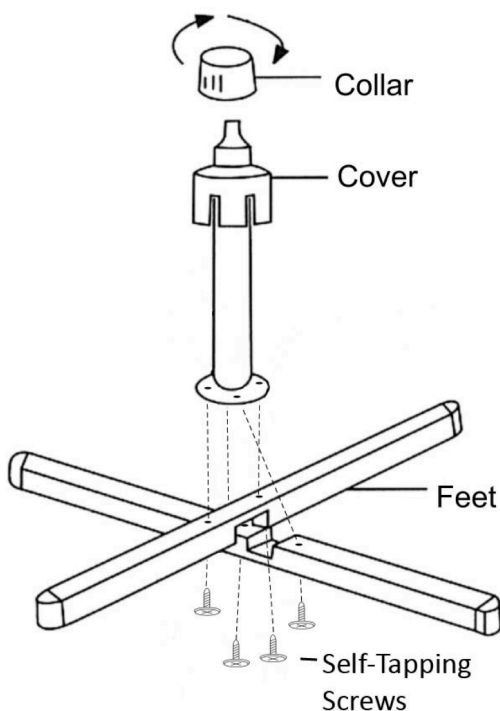

- Interlock the two feet, place the lower shaft on top of the feet, and fix with four screws.

## ASSEMBLY (CONTINUED)

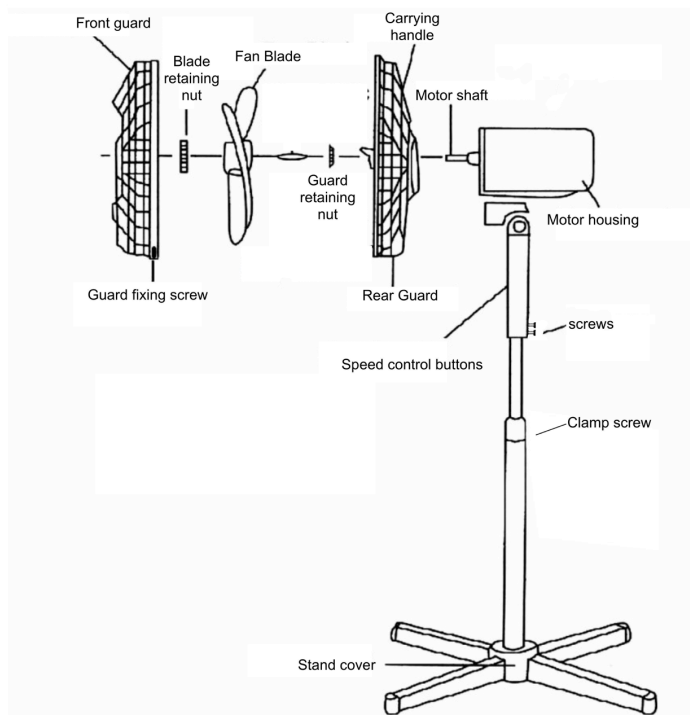

- Slide the motor assembly onto the telescopic shaft, and tighten the thumb screw.
- Loosen the shaft clamp screw, pull the telescopic shaft to the required height, and re-tighten the clamp screw.
- Rotate the guard retaining nut anticlockwise to remove it from the motor housing. Locate the rear grille on to the motor housing and fix in place with the guard retaining nut.
- Place the blades on the motor shaft, and locate the peg on the shaft into the recess at the back of the blades. Fix the blades in place using the blade retaining nut. Rotate anticlockwise to tighten (it has a left-handed thread)
- Attach the front guard to the rear grille using the guard clamp, and tighten the fixing screw to retain in place.

## OPERATION

- Plug the mains lead into a 13 Amp mains socket.
- If connecting via an extension lead, make sure that the lead is rated at 3 Amps or more, and that it is fully unwound. If any other appliances are connected to the same extension lead, make sure that it is rated for the total power of all appliances connected.

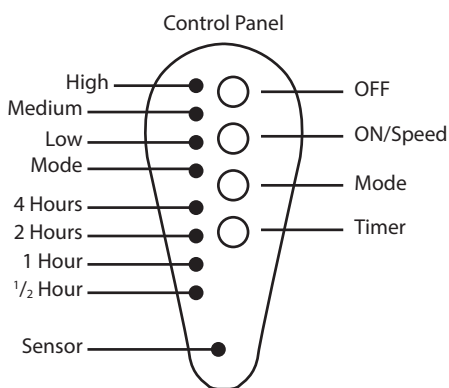

- Switch the appliance on at the mains socket.
- Press the ON/SPEED button on the control panel (9) to start, then press it again to select the speed:
  - The L M or H indicator illuminates to show which speed is selected (Low, Medium or High)
  - The MODE switch can be used to select normal operation ("MODE" indicator illuminates red) or to simulate a natural breeze ("MODE" indicator illuminates green)
  - It is normal for the motor to become warm in normal use.
  - Unplug the appliance from the mains when not in use.
- To select oscillation, press the oscillation control on top of the motor housing. To turn off oscillation, pull the oscillator lever upwards.

## TIMER

The timer can be used to switch the fan off automatically after a period of time in increments of 30 minutes up to 7½ hours. To activate the time, press the TIMER button repeatedly until the indicator shows the required number of hours. (Add up the times of the indicators that are illuminated – if "4 hours" and "1 hour" are illuminated then the timer is set for 5 hours). The fan will switch off after the selected time.

## REMOTE

The remote control can be used to switch the fan on and off, to select the speed and the operating mode, and to set the timer. The buttons on the remote control handset operate exactly the same as the buttons on the control panel. Oscillation cannot be controlled from the remote control handset.

Remote Control

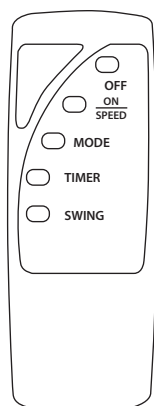

## PAT TESTING

When used in an office environment, this product must be safety-tested yearly by a qualified electrician (PAT Tested) in order to comply with the Electricity at Work Regulations.

We recommend that it is PAT tested regularly when used in a domestic environment.

## GENERAL SAFETY REQUIREMENTS

Domestic wiring must be tested periodically by a qualified electrician at least once every 10 years or at every change of occupancy. For office and retail premises, and buildings such as village halls, the wiring must be inspected at least once every 5 years. It is recommended that all buildings be fitted with smoke alarms (it is mandatory for new buildings).

## OPERATING COSTS

At time of going to press, the average cost of electricity is £0.15 per unit (kilowatt-hour). The amount you are being charged will be shown on your electricity bill. At this cost, the EH1826 will cost 14p per day to run on the highest speed setting.

## MAINTENANCE

Before cleaning, turn the appliance off, and disconnect from the mains supply. The appliance may then be cleaned using a damp cloth with a drop of washing-up liquid to remove any dust or dirt from the case. Do not use stronger detergents or solvents as these may damage the paint finish.

Using a dry 1" (25mm) paint-brush, remove any dust from the grilles.

If the mains lead is damaged, it must be replaced by the manufacturer or an authorised service centre.

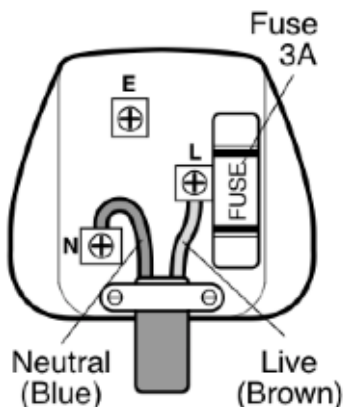

If the mains plug needs to be replaced, proceed as follows:

- Connect the brown wire to the terminal labelled "L".
- Connect the blue wire to the terminal labelled "N".
- Make sure that the cord-grip is positioned correctly (over the outer sheath of the cable) and it fully tightened.
- If the plug is fitted with a 13 A or 5 A fuse, replace it by a 3 A fuse.

## DISPOSAL AND RECYCLING

You must not dispose of this appliance with domestic household waste.

Most local authorities have specific collection system for appliances and disposal is free of charge to the end-user. When replacing an existing appliance with a similar new appliance your retailer may take the old appliance for disposal.

## TECHNICAL SPECIFICATION

Dimensions:.....	1340x600x600mm	Operating Current:.....	0.17A
Weight:.....	2.8kg	Air Speed:.....	2.957 m/s
Power Supply:.....	230V~	Noise:.....	60 dBA
Power Consumption: .....	40W (max)	Service Value:.....	1.326 m3/W.min
Air Flow:.....	3222 m3/h (max)		

## SERVICE WARRANTY

Prem-i-Air guarantees the product free from defects in materials and workmanship for a period of 2 years. Should this appliance be operated under conditions other than those recommended, at voltages other than the voltage indicated on the appliance, or any attempts made to service or modify the appliance, then the warranty will be rendered void. The product you buy may sometimes differ slightly from illustrations. This warranty is in addition to, and does not affect, your statutory rights.

If you have any problems with this product, please call our Help Desk on **(0845) 459 4816**.