



MeacoFan

Seftē[®] 6”

Portable Battery Air Circulator

Sēf-tee: “Quiet, gentle and undisturbed”; in Old English

Instruction Manual

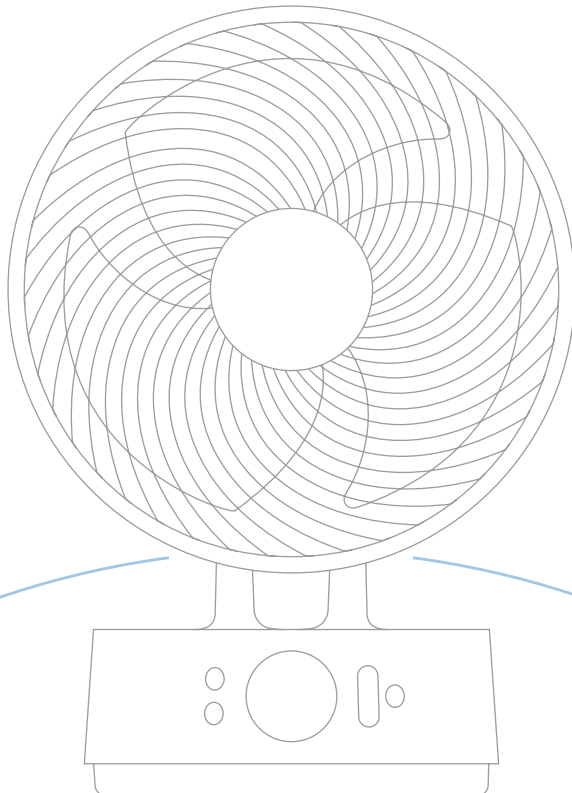

Thank you for choosing Meaco

Thank you for choosing Meaco, we really appreciate it. We built the Sefté® range of air circulators after years of research and customer feedback, engineering the perfect cooling product for you and your family that not only provides you with enhanced cooling but is functional in its design and fits into your home.

This manual contains important information on the use and care of your air circulator. Please take some time to read this manual to take full advantage of your air circulators' many benefits and features.

Contents

Safety information	1
Register your Meaco warranty	3
What's included	4
Product identification	5
Operation	6
Battery mode	9
Maintenance	11
Storing	13
Troubleshooting	13
Meaco customer care	14
Specifications	14
Warranty terms & conditions	15

Safety information

Important safety instructions



This air circulator must not be used in rooms under the following conditions: potentially explosive atmosphere, aggressive atmospheres, featuring a high concentration of solvents or an extremely high ratio of dust.

Magnets: The remote control contains magnets. Please note the following: Pacemakers and defibrillators may be affected by magnets. If this affects you then please do not put the remote control in a pocket and warn anyone who is likely to use the air circulator or the remote that it has a magnet. Credit cards and data cards can also be affected by magnets and should not be placed near to the air circulator remote.

Keep children away: Do not allow children to play with or around this unit, which could result in injury. Be sure the unit is inaccessible to children when not attended. This appliance is not intended for use by persons (including children) with reduced physical, sensory or mental capabilities, or lack of experience and knowledge, unless they have been given supervision or instruction concerning use of the appliance by a person responsible for their safety.

Protect mains adaptor from damage: Never operate a unit with a damaged mains adaptor, as this may lead to electrical or fire hazards. If the mains adaptor is damaged, it must be replaced by a mains adaptor of the same type and amperage rating.

Extension cords: Extension cords must be grounded and able to deliver the appropriate voltages to the unit.

Handle with care: Do not drop, throw or crash the air circulator. Rough treatment can damage the components or wiring and create a hazardous condition.

Run on a stable surface: Always operate the air circulator on a stable, level surface, for example the floor or a strong counter, so that the air circulator cannot fall and cause injury.

Keep electrical components dry: Never allow water inside the air circulator's electrical components. If these areas become wet for any reason, thoroughly dry them before using the air circulator. If in doubt, do not use the air circulator and consult a qualified electrician or a Meaco approved engineer.

The operator must make the operating instruction available for the user and make sure that the user does understand the manual.

Instructions about the WEEE



Correct disposal of this product (Waste Electrical & Electronic Equipment)

This marking indicates that this product or accessories should not be disposed of with other household waste at the end of their working life. To prevent possible harm to the environment or human health from uncontrolled waste disposal, please separate these items from other types of waste and recycle them responsibly to promote the sustainable reuse of material resources. Users should contact either the retailer where they purchased this product, or their local government, for details of where and how they can take these items for environmentally safe recycling.

Declaration of conformity

Hereby, Meaco declares that this radio equipment is in compliance with Directive 2014/35/EU and with the relevant statutory requirements. The full text of the EU declaration of conformity and the UK declaration of conformity is available at the following internet address:
<https://www.meaco.com/pages/compliance-data>.

Register your Meaco warranty

Your Meaco air circulator comes with a free 3-year warranty, simply register your details online and you'll be covered for parts and labour for 3 years from the date of purchase, subject to the terms and condition of the warranty.

Where to find your air circulators serial number

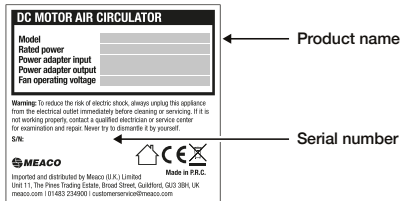

The serial number can be found on the rating label underneath the base of your air circulator.

Remember to keep a copy of your purchase receipt safe, you will need to show this to our Customer Service team should you need to make a warranty claim.

Ways to register your Meaco warranty



Register online

Visit our website to register your free 3-year warranty online:
<https://www.meaco.com/pages/register-your-warranty>

Register by phone

Call our Customer Service team to register your free 3-year warranty over the phone: 01483 234900
Opening times: Monday - Friday 9am - 5:30pm

What's included

Carefully unpack the air circulator. Keep all packaging materials away from children. We recommend flat packing and keeping hold of the box should you need it in the future.

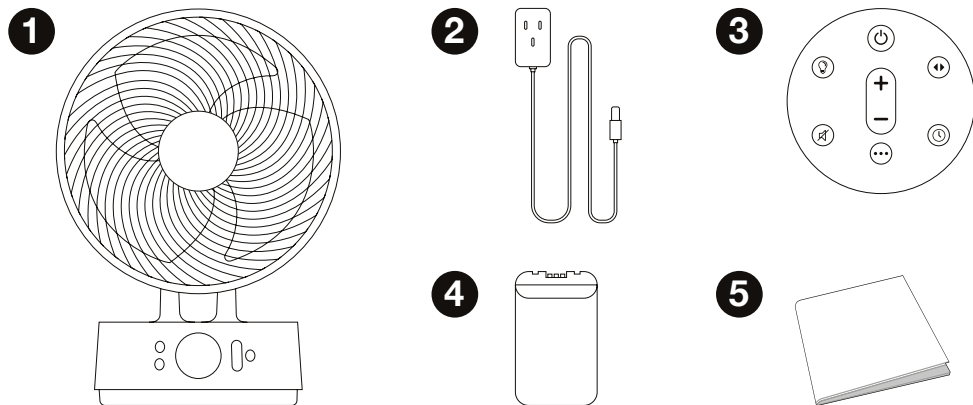

1. Meaco Sefta® 6" Portable Battery Air Circulator
2. Mains adaptor
3. Remote control
4. Battery pack
5. Instruction manual

Product identification

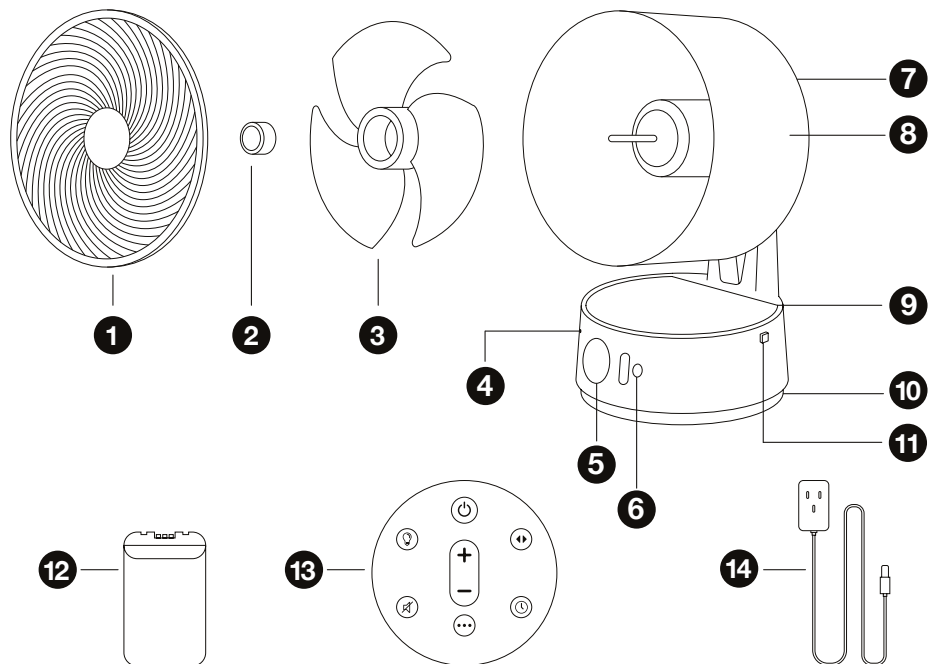

1. Front grille
2. Locking cap
3. Blades
4. Battery status light
5. Display
6. Interface
7. Handle

8. Back grille
9. Battery compartment cover
10. Mains adaptor input
11. Battery compartment cover release button
12. Battery pack
13. Remote control
14. Mains adaptor

Operation

When the air circulator is plugged into the mains, the air circulator will beep once and the battery status light above the power button will turn on, the air circulator is in Standby mode.

Interface

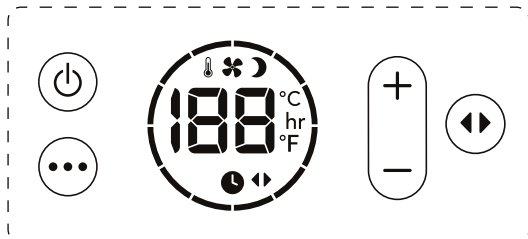

 **Power button:** Press the standby button once to turn the air circulator on and press the standby button again to turn the air circulator off. To turn the air circulator power off, unplug it from the mains.

 **Mode:** Press the mode button to move through 3 modes: Normal, Night and ECO.

 **Normal** The air circulator will run as normal on the selected fan speed between 1 and 12.

 **Night** The interface and battery status light will turn off and the buttons will no longer beep when pressed. The fan speed will reduce by 1 step every hour until it reaches fan speed 1. When changing a setting (e.g. the fan speed) the display will turn on briefly until set and then turn off again.

 **ECO** The fan speed will automatically change depending on the room temperature.

Room temperature	<19°C	20°C	21°C	22°C	23°C	24°C	25°C	26°C	27°C	28°C	29°C	>30°C
Fan speed	1	2	3	4	5	6	7	8	9	10	11	12



Increase fan speed: Press the + fan speed button to increase the fan speed between 1 and 12. When 12 is reached, pressing this button again will take you back to 1.



Decrease fan speed: Press the - fan speed button to decrease the fan speed between 1 and 12. When 1 is reached, pressing this button again will take you back to 12.



Horizontal oscillation: Press the horizontal button to turn on horizontal oscillation.

Vertical oscillation: Manually adjust the air circulator head in order to change its vertical angle.

After a setting is adjusted, the interface will revert back to displaying the room temperature and the set mode (unless in Night mode where the interface will turn off).

Remote control

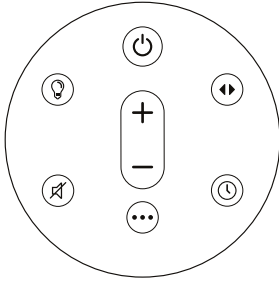

- Before using the remote control, remove the plastic tab.
- The remote control is magnetic and can be attached to the centre of the air circulator face - make sure the buttons are facing inwards.
- The remote control has a range of approximately 4 metres.

The following functions are only available via the remote control.



Timer: Use the timer button to set an ON or OFF timer. To remove either the ON or OFF timer, press the timer button until you reach '00 hrs'.

Timer on When the air circulator is in standby mode, use the timer button to move between 1 and 12 hours in which the air circulator will turn on. Once the desired number of hours has been reached on the display, the air circulator will beep twice. The interface will display the number of hours in which the air circulator will turn on e.g. '03 hr'.

Timer off When the air circulator is on, use the timer button to move between 1 and 12 hours in which the air circulator will turn off. Once the desired number of hours has been reached on the display, the air circulator will beep twice (unless it is in Night mode). The interface will display a timer symbol under the room temperature. If in Night mode, the interface will turn off.



Light: Press the light button to turn off the display and battery status light above the power button. Press again to turn back on.



Mute: Press the mute button to silence the buttons on the air circulator. The air circulator will beep when the mute button is pressed and then will no longer beep when any other buttons are pressed. Press the mute button again to unmute. Hold the mute button down for more than 5 seconds to change the temperature on the display between °C and °F.

Battery mode

The air circulator can be used in battery only mode, meaning the mains adaptor is not required.

- Battery type required: 2500 mAh Li-ion rechargeable battery.

Battery installation

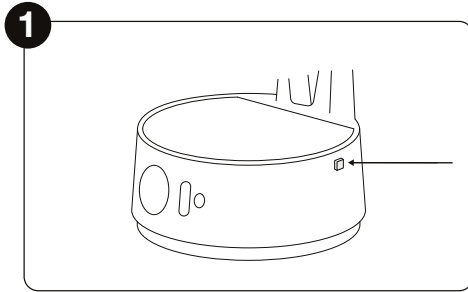

Press the button on the right hand side of the air circulator to release the lid.

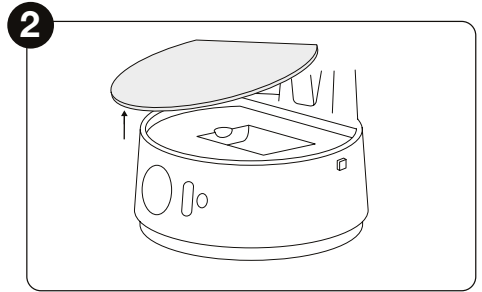

Remove the battery pack compartment cover.

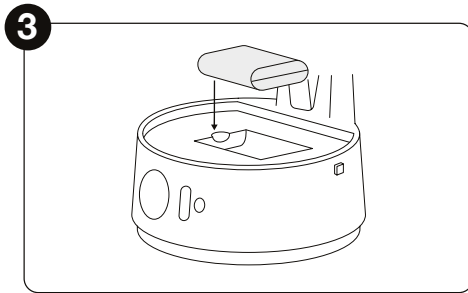

Insert the battery pack into the battery compartment.

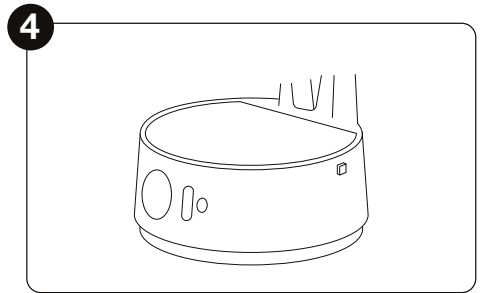

Put the battery pack compartment cover back in place.

Charging the battery

When charging the battery, actual energy consumption can be greater than the values in the Specifications section.

Charging the battery to 100% will take approximately 3 hours.

To charge the battery, simply make sure the battery is in place in the air circulator (as per the instructions above) and plug the air circulator into the mains using the mains adaptor.

Battery status

Above the power button on the air circulator interface is an LED light showing the battery status.

Solid white	Fully charged
Flashing white	Charging - less than 100% charge
Solid red	Less than 20% charge
Flashing red	Less than 10% charge

Battery life

Battery life		
Fan speed	No oscillation	Full oscillation
1	26.5 hours	5.5 hours
2	21 hours	5 hours
3	18 hours	5 hours
4	17 hours	5 hours
5	15 hours	4.5 hours
6	13 hours	4 hours
7	11 hours	4 hours
8	9 hours	4 hours
9	7.5 hours	4 hours
10	7 hours	3.5 hours
11	5 hours	3.5 hours
12	4.5 hours	3 hours

Battery disclaimer

Lithium-ion batteries are designed to go through a continuous cycle of being recharged - if this happens consistently they will continue to perform at their best. If the battery is not recharged for a period of more than 3 months the battery performance will reduce by 50%. Due to the nature of our products, it is more than likely the battery will not be recharged over the winter period and therefore suffer a performance decrease. We therefore recommend you recharge your fan every 3 months for 1.5 hours. If you forget to do this and find the performance of the battery has been reduced, you can purchase a new lithium-ion battery.

The batteries used in our fans are the most up to date form of lithium battery, the performance decrease indicated above is just the nature of this type of battery. We use lithium-ion batteries as they are the most efficient battery. They are rechargeable and charge in the shortest amount of time keeping energy costs to a minimum. We therefore believe the positives of using lithium-ion batteries outweigh the negatives.

Maintenance

Cleaning your air circulator

To ensure your air circulator is always performing at its best, it's important to regularly clean it.

- Always unplug your air circulator from the mains before cleaning.
- Do not allow the air circulator to get wet.

Use a soft dry cloth to clean the external and internal parts of the air circulator. To access the fan blades, following the steps below:

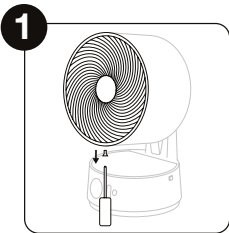

Using a screwdriver, unscrew the screw at the bottom of the air circulator head.

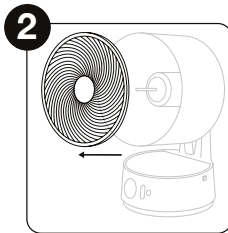

Hold the grille on the left and right side of the air circulator and rotate anti-clockwise to remove the grille from the head.

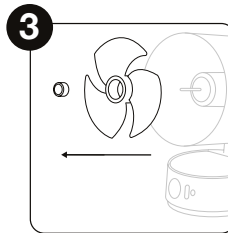

Unscrew the locking cap in the centre of the air circulator in a clockwise motion to remove the fan blades.



Reverse the steps above to put the air circulator back together. Make sure the locking cap is tightened securely.

Replacing the remote control battery

If the remote control fails to work within 4 metres of the air circulator, replace the battery.

Battery type: CR2025 or CR2032. To replace the battery follow the steps below:

Keep batteries away from children!

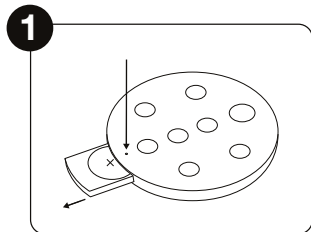

1 Push the safety release (below the Mode button) with the end of a paper clip to release the battery compartment.

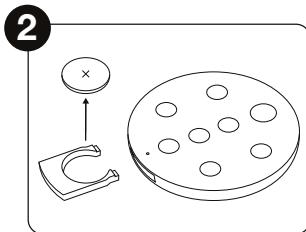

2 Replace the battery making sure the polarity is correct.

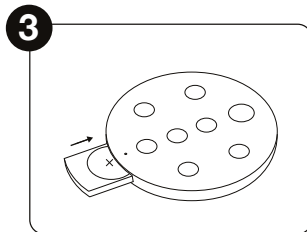

3 Push the battery and battery compartment back into the remote control.

Storing

When the air circulator is not going to be used for more than 3 months, we recommend charging the battery for 1.5 hours and then removing it from the air circulator to prevent a reduction in the battery's performance. 1.5 hours will not charge the battery to 100%, it will charge the battery to 50% which is the optimum charge to prevent a reduction in performance. Repeat the charging process once every 3 months. Store the battery in a cool, dry place away from children.

Store the air circulator in a clean, dry place in its original box.

Tip! The air circulator can also be used in winter to help distribute warm air more effectively within a room or it can be used in conjunction with a dehumidifier to circulate dry air and dry your laundry faster.

Troubleshooting

If you come across a problem with your air circulator, check the table below and try the suggestions. If the problem persists, contact Meaco.

Error	Action
Fan blades not moving	Check the adaptor is connected correctly
Increased noise level	Clean the fan blades Make sure the locking cap is tightened securely
E1	Contact Meaco
E2	Contact Meaco
E3	Contact Meaco
E4	Contact Meaco
E5	Contact Meaco

Meaco customer care

If you have a question about your Meaco air circulator, contact our Customer Service team who will be happy to help. Make sure you have your serial number and details of where and when you purchased your air circulator.

Specifications

Some specifications will differ depending on how your air circulator is powered: by mains adapter or by battery. The specifications below are for when the air circulator is powered by mains adapter. For the full list of specifications visit eu.meaco.com. Information to identify the model(s) to which the information relates to MeacoFan Sefta® 6 Portable Battery Air Circulator.

Description	Symbol	Value	Unit
Maximum fan flow rate	F	[8.4]	m ³ /min
Fan power input	P	[8.1]	W
Service value	SV	[1.0]	(m ³ /min)/W
Standby power consumption	PSB4	[≤0.5]	W
Fan sound power level	LWA	[54]	dB(A)
Maximum air velocity	c	[4.2]	m/s
Noise level	LWA	[22.7]	dB(A)
Voltage	-	[220-240]	V
Power consumption	-	[18]	W
Dimensions (HWD)	-	[211x181x324]	mm
Nett weight	-	[1.7]	kg
Measurement standard for service value	Veordnung (EU) Nr. 206/2012 + (EU) Nr. 2016/2282 EN IEC 60879:2019 EN 50564:2011 EN 60704-1:2010 + A11:2012 EN IEC 60704-2-7:2020		

Contact details for obtaining more information

Website: <https://meaco.com/pages/contact-us>
 E-Mail: customerservice@meaco.com
 Telephone: 01483 234900
 Address: Unit 11, The Pines Trading Estate, Broad Street,
 Guildford, GU3 3BH, United Kingdom

Warranty terms and conditions

There is a three-year manufacturer's warranty on your air circulator from the date of delivery. Within the three-year warranty all manufacturing defects will be repaired free of charge.

The following applies:

1. Any repair or replacement of your air circulator or its components during the warranty period will not result in an extension of the warranty period.
2. If your air circulator has been opened or tampered with or not genuine components have been fitted by yourself or anyone other than a Meaco engineer, your warranty is invalid. This does not include removing the air circulator grille to clean the fan blades.
3. Components subject to normal wear and tear, the Li-ion battery, remote control and mains adaptor are not covered by the warranty.
4. The warranty is only valid on presentation of the original, unaltered and date-stamped purchase receipt. If you are unable to produce proof of purchase, the warranty on your air circulator is invalid.
5. The warranty does not cover damage caused by actions that deviate from those as described in the instruction manual or by neglect.
6. The warranty does not cover faults caused by dirt or by third-party products.
7. Using a third-party switching device that turns the air circulator on or off via the mains will invalidate the warranty.
8. The warranty does not cover accidental damage.
9. All claims for compensation, including consequential damage, will not be entertained.

For the full list of the warranty terms and conditions please visit: www.meaco.com/warranty-terms.

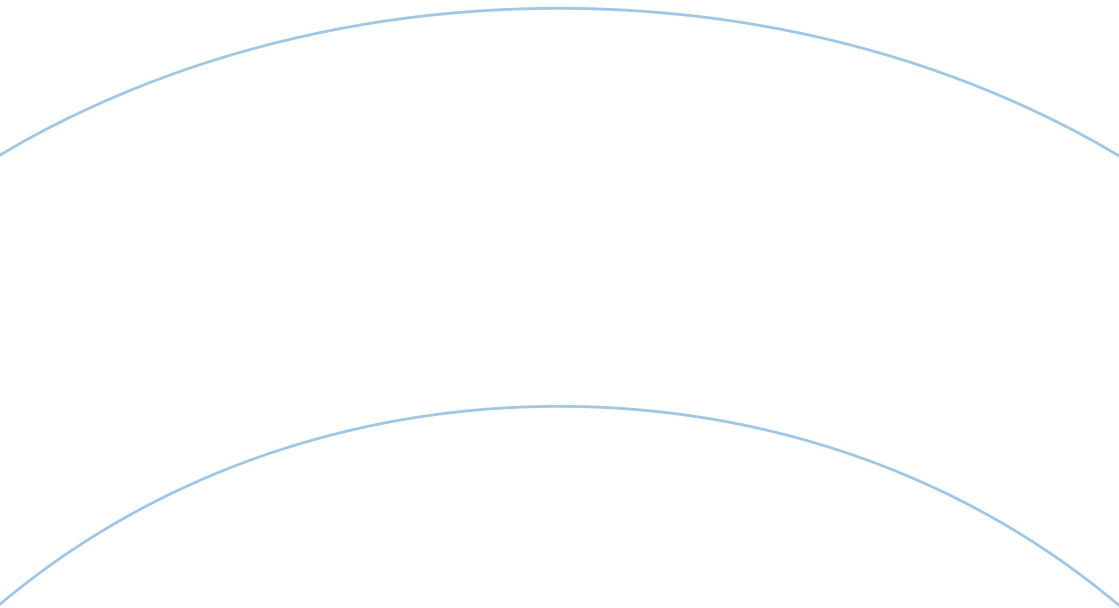

Unit 11, The Pines Trading Estate, Broad Street,
Guildford, GU3 3BH, United Kingdom

meaco.com



The mark of
responsible forestry